

Surname	Centre Number	Candidate Number
First name(s)		0



**GCSE**

3300U20-1



**WEDNESDAY, 16 NOVEMBER 2022 – MORNING**

**MATHEMATICS  
UNIT 2: CALCULATOR-ALLOWED  
FOUNDATION TIER**

1 hour 30 minutes

**ADDITIONAL MATERIALS**

A calculator will be required for this examination.  
A ruler, a protractor and a pair of compasses may be required.

**INSTRUCTIONS TO CANDIDATES**

Use black ink or black ball-point pen. Do not use gel pen or correction fluid.

You may use a pencil for graphs and diagrams only.

Write your name, centre number and candidate number in the spaces at the top of this page.

Answer **all** the questions in the spaces provided.

If you run out of space, use the additional page at the back of the booklet. Question numbers must be given for all work written on the additional page.

Take  $\pi$  as 3.14 or use the  $\pi$  button on your calculator.

**INFORMATION FOR CANDIDATES**

You should give details of your method of solution when appropriate.

Unless stated, diagrams are not drawn to scale.

Scale drawing solutions will not be acceptable where you are asked to calculate.

The number of marks is given in brackets at the end of each question or part-question.

In question 5(c), the assessment will take into account the quality of your linguistic and mathematical accuracy in writing.

In question 12, the assessment will take into account the quality of your organisation and communication.

For Examiner's use only		
Question	Maximum Mark	Mark Awarded
1.	3	
2.	4	
3.	1	
4.	2	
5.	7	
6.	4	
7.	2	
8.	4	
9.	2	
10.	2	
11.	3	
12.	5	
13.	9	
14.	2	
15.	2	
16.	4	
17.	4	
18.	5	
<b>Total</b>	<b>65</b>	

3300U201  
01



NOV223300U20101

**Formula List – Foundation Tier**

**Area of trapezium**  $= \frac{1}{2} (a + b)h$

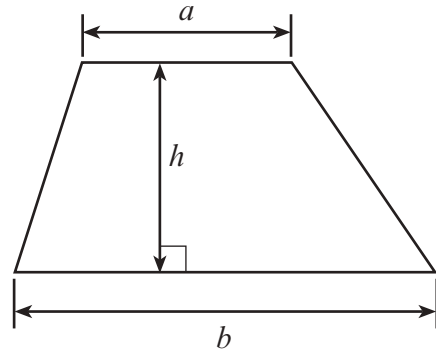

1. (a) One of the calculations below is incorrect.  
Circle the incorrect calculation.

[1]

$78 + 9952 = 10030$

$875 \div 35 = 25$

$3685 - 2852 = 833$

$452 \times 63 = 28466$

$89775 \div 45 = 1995$

.....

- (b) One of the numbers below is a multiple of 38.  
Circle the multiple of 38.

[1]

2

19

338

388

3838

.....

- (c) Computers cost £432 each.  
How many can be bought with £9876?

[1]

.....

.....



2. (a) The special name for one of the quadrilaterals below is a kite.  
Circle the kite.

[1]

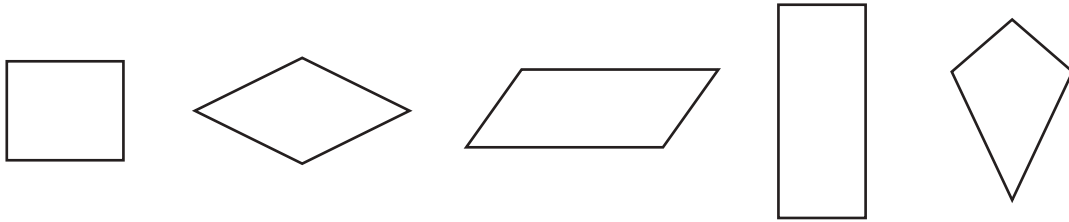

- (b) One of the angles shown below is an acute angle.  
Circle the acute angle.

[1]

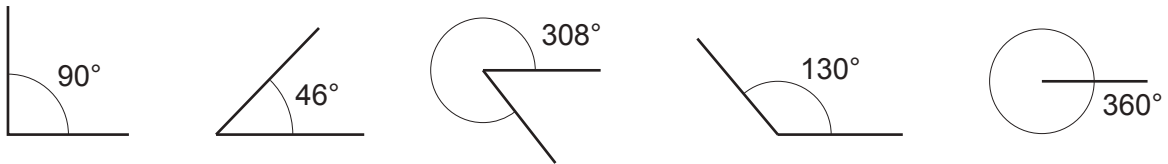

- (c) One of the diagrams below shows a chord of a circle.  
Circle the correct diagram.

[1]

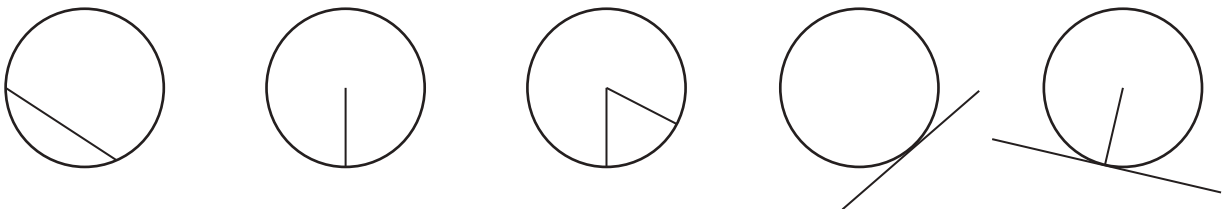

- (d) Add two squares to the four shaded squares shown below so that the complete diagram forms the net of a cube.

[1]

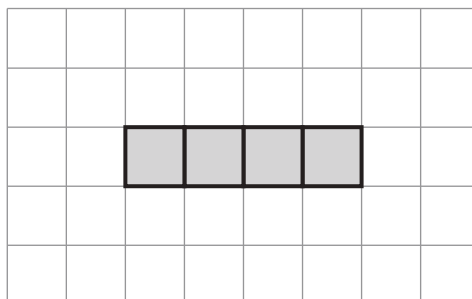

3. Complete the calculation below, by finding the **two** missing digits. [1]

5	.....	×	4	7	=	2	4	.....	1
---	-------	---	---	---	---	---	---	-------	---

.....

.....

4. The point  $P$  is plotted on the grid below.

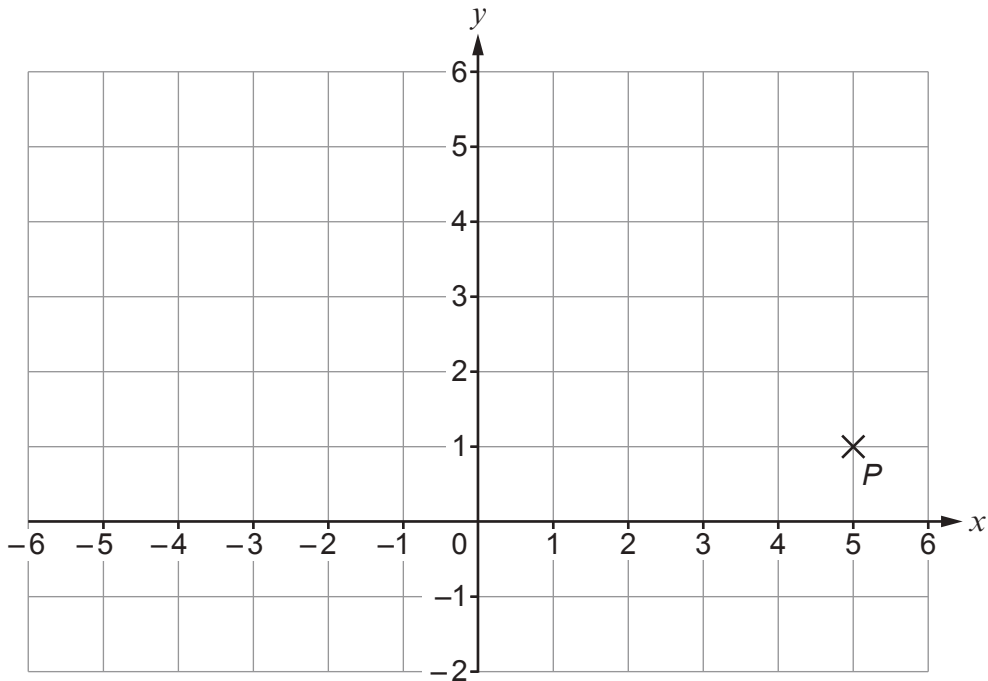

Steve writes the coordinates of  $P$  as 1; 5.

Explain what is wrong with the way Steve has written the coordinates. [2]

.....

.....

.....

.....



5. (a) Simplify  $3a + 2a - a$ . [1]

.....

(b) (i) Draw Diagram 4 in the sequence below. [1]

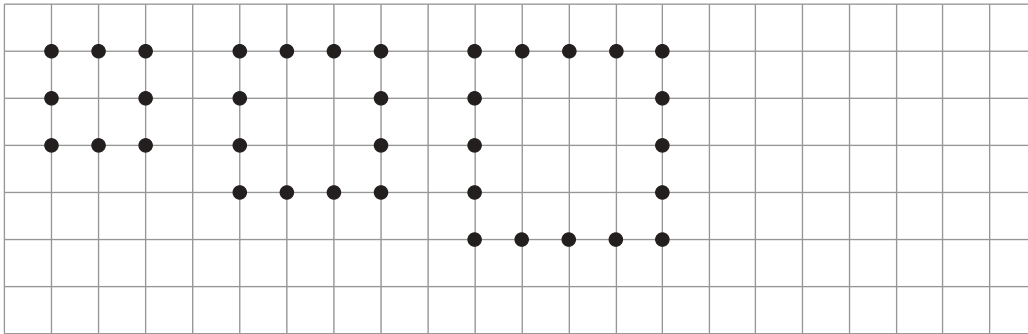

Diagram 1

Diagram 2

Diagram 3

Diagram 4

(ii) How many dots will there be in Diagram 6? [2]

.....  
 .....  
 .....  
 .....

(c) *In this part of the question, you will be assessed on the quality of your linguistic and mathematical accuracy in writing.*

Find the value of  $7w + 5y$  when  $w = 36$  and  $y = 29$ .  
 You must show all your working.

[2 + 1 W]

.....  
 .....  
 .....  
 .....



6. The 22 pupils in a class were asked, "What is your favourite pet?"  
The pets chosen by the pupils were dog, cat, rabbit and hamster.  
Some of the results are shown in the bar chart below.

9 pupils in the class chose either rabbit or hamster.  
The **modal** pet is rabbit.

- (a) Complete the bar chart by drawing the two missing bars.

[2]

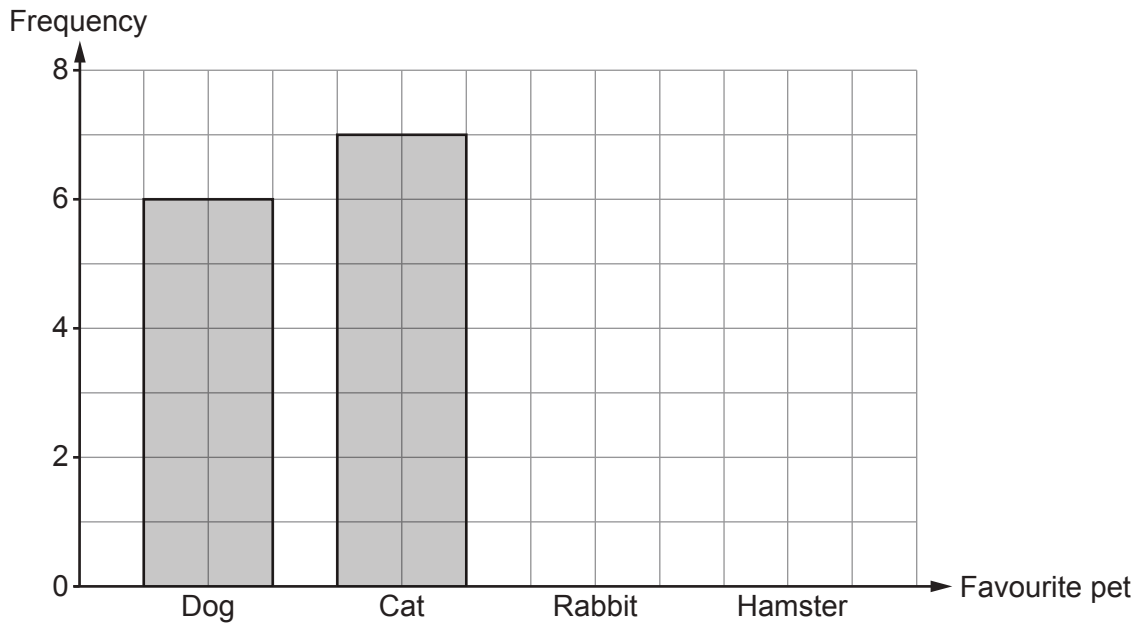

.....

.....

.....

.....

- (b) One of these pupils is chosen at random.  
What is the probability that this pupil's favourite pet is a cat?

[2]

.....

.....



7. Most numbers have an **even** number of factors.

For example,

7 has **two** factors: 1 and 7.

8 has **four** factors: 1, 2, 4 and 8.

Some numbers have an **odd** number of factors.

There is one number between 14 and 20 that has an **odd** number of factors.

Find this number.

Write down all the factors of this number.

You must show all your working.

[2]

.....

.....

.....

.....

.....

.....

.....

.....

.....

.....

.....

.....

The number is .....

The factors of this number are .....

8. Calculate each of the following.

(a)  $2.7$  squared

[1]

.....

(b) the square root of  $11.56$

[1]

.....

(c) 60% of 28

[2]

.....

.....





9. Shelley thinks of a number.

$\frac{1}{5}$  of her number is 46.

What is Shelley's number?

[2]

.....

.....

.....

.....

10. Mark is making an 8-sided spinner.  
All of the sections on his spinner are identical.

Mark is going to label each of the sections with one of three colours: blue (B), yellow (Y) or red (R).

Label the spinner below so that when the spinner is spun:

- landing on red and landing on blue are **equally likely**  
AND
- it is **likely** that the spinner lands on yellow.

[2]

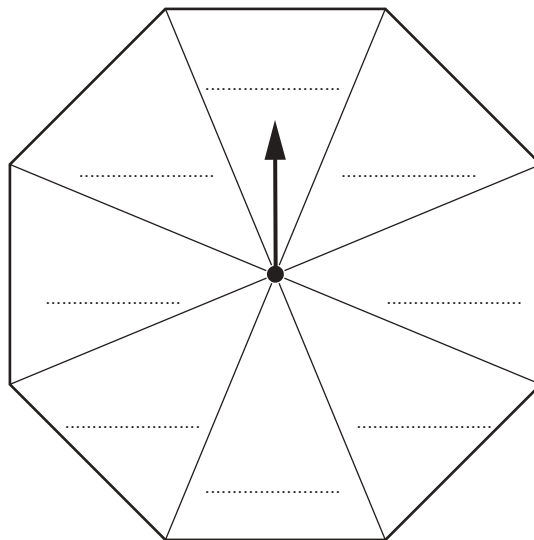

11. (a) Enlarge the shape below by a scale factor of 3.

[2]

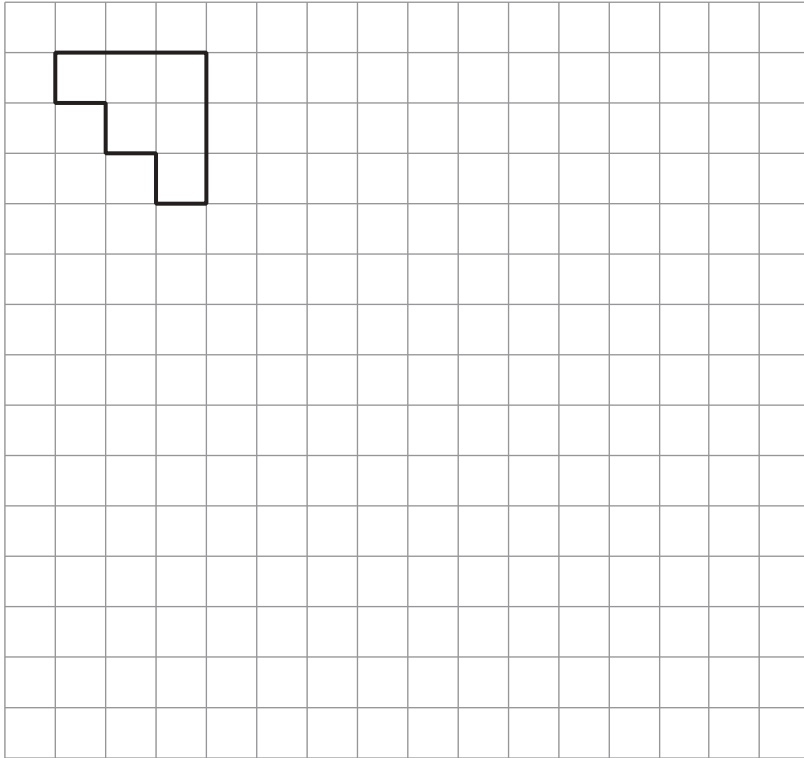

- (b) Translate the shape below 2 squares to the left and 4 squares down.

[1]

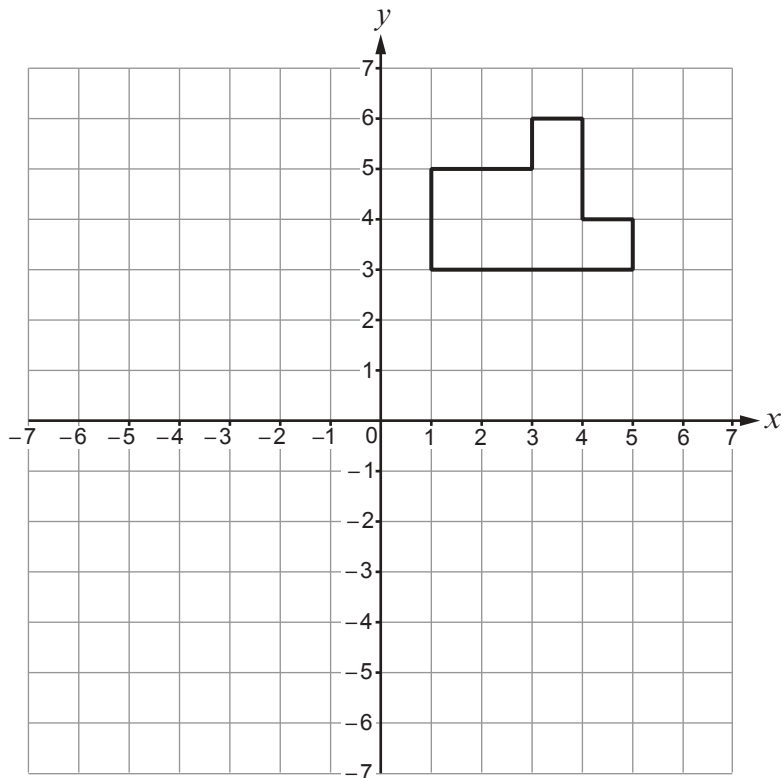

12. In this question, you will be assessed on the quality of your organisation and communication.

In the diagram below,  $AF$  is a straight line.

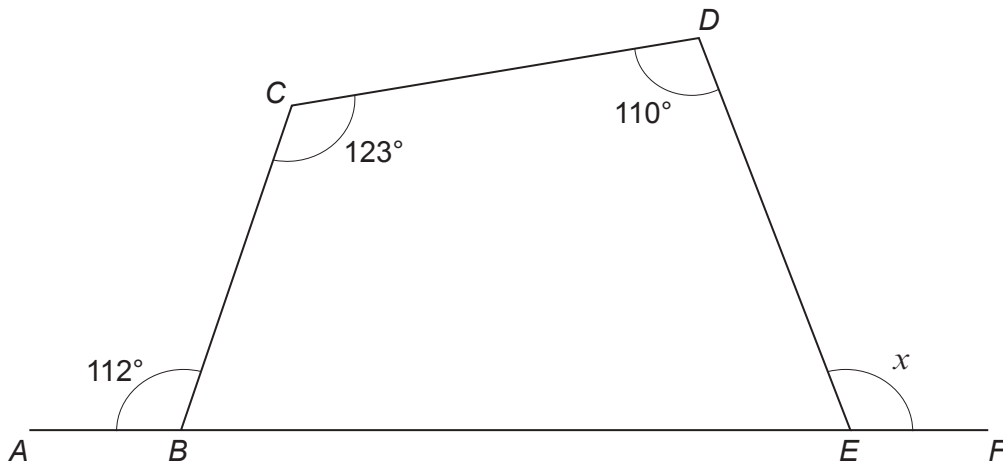

Diagram not drawn to scale

Calculate the size of angle  $x$ .  
You must show all your working.

[4 + 1 OC]

.....

.....

.....

.....

.....

.....

.....

.....

.....

.....

.....

.....

.....

.....

.....

.....

.....

.....

.....



13. Laura puts 90 counters in a bag.  
Each counter is red or blue or yellow.

Laura wants to draw a pie chart to show the number of counters of each colour.  
The table below shows some of the information that she needs.

	Number of counters	Pie chart angle
Red	25	.....
Blue	.....	180°
Yellow	.....	.....
Total = 90		

- (a) Complete the table.  
You must show all your working.

[5]

.....

.....

.....

.....

.....

.....

.....

.....



(b) Complete the pie chart to show the results.

[2]

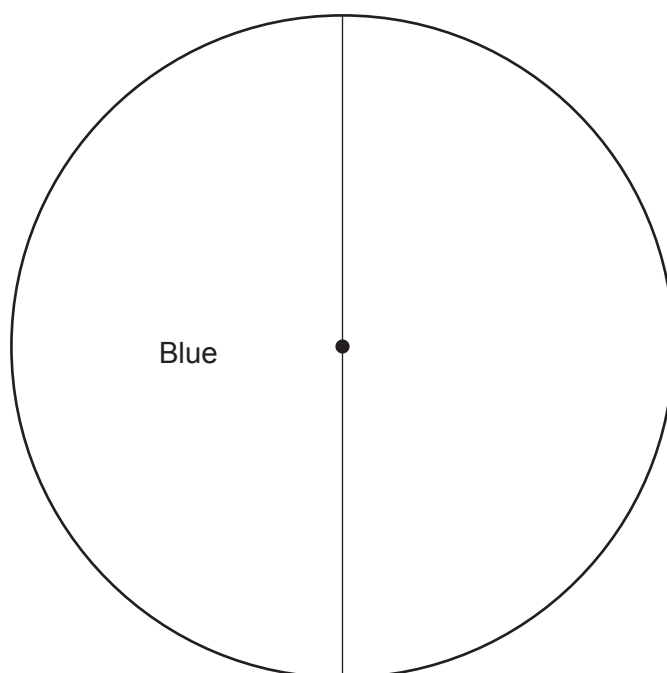

(c) Laura chooses a counter at random from the bag.  
Calculate the probability that this counter is either red or blue.

[2]

.....

.....

.....

.....



14. Find the whole number that satisfies all of the following conditions:

- It is a whole number between 15 and 35 inclusive.
- The number is a multiple of 2 but not a multiple of 4.
- 3 is a factor of this number, but 9 is **not** a factor of this number.

[2]

.....

.....

.....

.....

.....

.....

.....

.....

.....

.....

The whole number is .....

15. Calculate  $\frac{15 \cdot 4^2}{14 \cdot 59 - 7 \cdot 67}$ , correct to 1 decimal place.

[2]

.....

.....

.....

.....



16. 125 pupils were asked which one of four primary schools they attended.

(a) One of the pupils is chosen at random.

Complete the table below to find the probability that the pupil chosen went to Ysgol Bryn.

[2]

	Ysgol Aber	Ysgol Bryn	Ysgol Castell	Ysgol Dewi
Probability	0.08	.....	0.2	0.28

.....

.....

.....

.....

(b) How many of the 125 pupils went to Ysgol Dewi?

[2]

.....

.....

.....

.....

.....

.....



17. Point *A* and point *B* are shown in the scale drawing below.

- (a) Point *C* is 35 km from point *B* on a bearing of  $300^\circ$ .  
Complete the scale drawing to show the position of point *C*.

[2]

Scale: 1 cm represents 5 km

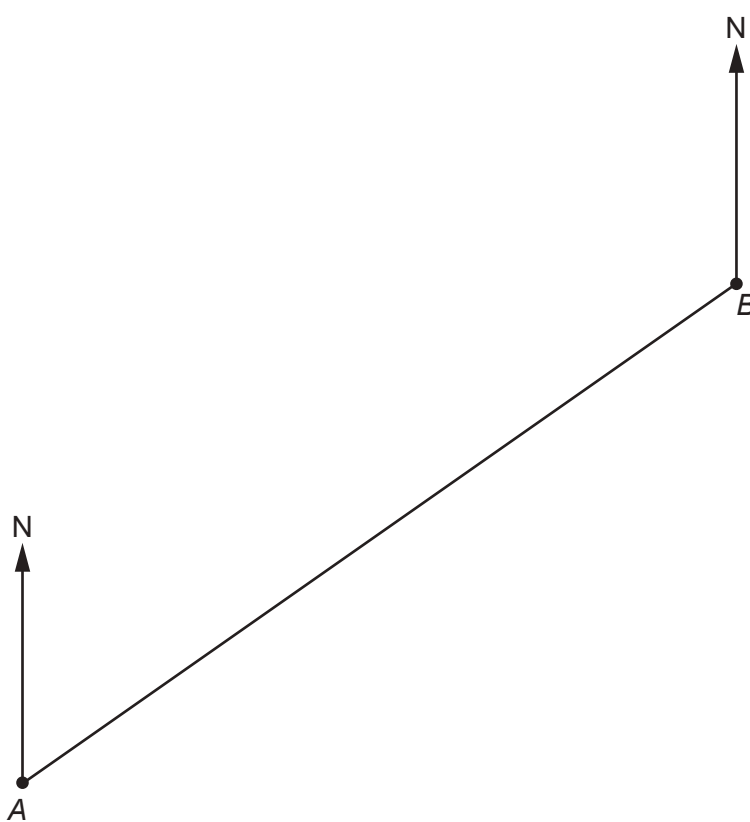

- (b) Use your scale drawing to calculate
- the **actual** length of *AC*, in kilometres,
  - the bearing of point *C* from point *A*.

[2]

.....

.....

Actual length of *AC* = ..... km

Bearing of point *C* from point *A* = .....  $^\circ$





18. (a) Express 21.76 as a percentage of 32.

[2]

.....

.....

.....

.....

.....

.....

.....

(b) Solve  $5t + 3 = 3t + 14$ .

[3]

.....

.....

.....

.....

.....

.....

.....

.....

.....

.....

**END OF PAPER**





**BLANK PAGE**

**PLEASE DO NOT WRITE  
ON THIS PAGE**



**BLANK PAGE**

**PLEASE DO NOT WRITE  
ON THIS PAGE**

