

Surname	Centre Number	Candidate Number
Other Names		0



GCSE

3300U40-1



**MATHEMATICS
UNIT 2: CALCULATOR-ALLOWED
INTERMEDIATE TIER**

WEDNESDAY, 14 NOVEMBER 2018 – MORNING

1 hour 45 minutes

ADDITIONAL MATERIALS

A calculator will be required for this examination.
A ruler, protractor and a pair of compasses may be required.

INSTRUCTIONS TO CANDIDATES

Use black ink or black ball-point pen. Do not use gel pen or correction fluid.
You may use a pencil for graphs and diagrams only.
Write your name, centre number and candidate number in the spaces at the top of this page.
Answer **all** the questions in the spaces provided.
If you run out of space, use the continuation page at the back of the booklet. Question numbers must be given for all work written on the continuation page.
Take π as 3.14 or use the π button on your calculator.

INFORMATION FOR CANDIDATES

You should give details of your method of solution when appropriate.
Unless stated, diagrams are not drawn to scale.
Scale drawing solutions will not be acceptable where you are asked to calculate.
The number of marks is given in brackets at the end of each question or part-question.
In question 5, the assessment will take into account the quality of your linguistic and mathematical organisation, communication and accuracy in writing.

For Examiner's use only		
Question	Maximum Mark	Mark Awarded
1.	5	
2.	3	
3.	4	
4.	4	
5.	5	
6.	5	
7.	4	
8.	5	
9.	5	
10.	4	
11.	3	
12.	6	
13.	3	
14.	4	
15.	3	
16.	4	
17.	6	
18.	7	
Total	80	



NOV183300U40101

Formula List – Intermediate Tier

Area of trapezium = $\frac{1}{2}(a + b)h$

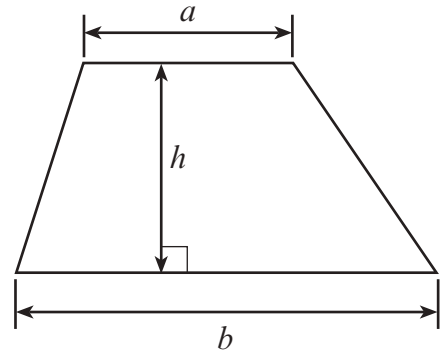

Volume of prism = area of cross-section \times length

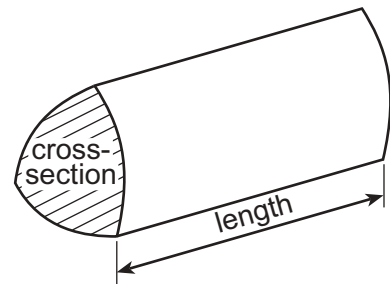

1. (a) Calculate $8 \cdot 2^2 + \sqrt{13}$.
Give your answer correct to 2 significant figures. [2]

.....

.....

.....

- (b) Find 57% of 83.5.
Give your answer correct to 1 decimal place. [3]

.....

.....

.....

.....

2. Circle either TRUE or FALSE for each statement given below. [3]

STATEMENT		
All circles are similar.	TRUE	FALSE
All squares are similar.	TRUE	FALSE
All triangles are similar.	TRUE	FALSE
All rectangles are similar.	TRUE	FALSE
All regular hexagons are similar.	TRUE	FALSE



3. One day, Gwyn was asleep for 8 hours and awake for the remaining hours.

Draw an accurate pie chart to illustrate this information.

[4]

Pie chart showing Gwyn's sleeping and waking hours.

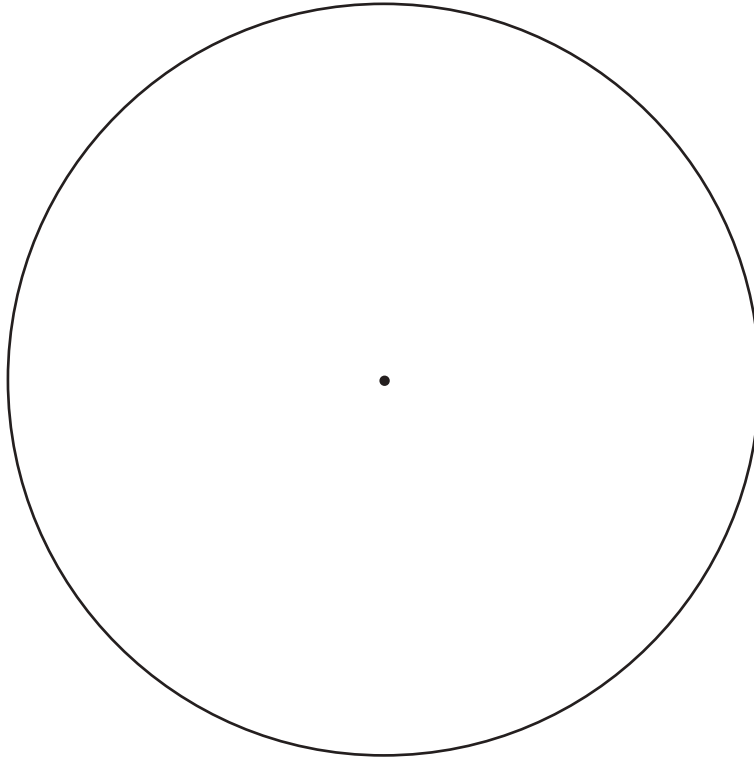

Space for working:

.....

.....

.....

.....

.....

.....



4. Choose any number.

Show that $\frac{1}{5}$ of 25% of your number = $\frac{1}{4}$ of 20% of your number. [4]

.....

.....

.....

.....

.....

.....

.....

.....

.....

.....

.....

.....

.....

.....

.....

.....

.....

.....

.....

.....

3300U401
05

5. In this question, you will be assessed on the quality of your organisation, communication and accuracy in writing.

ABC is an isosceles triangle and ABP is a straight line.

$AC = BC$ and $\widehat{ACB} = 76^\circ$.

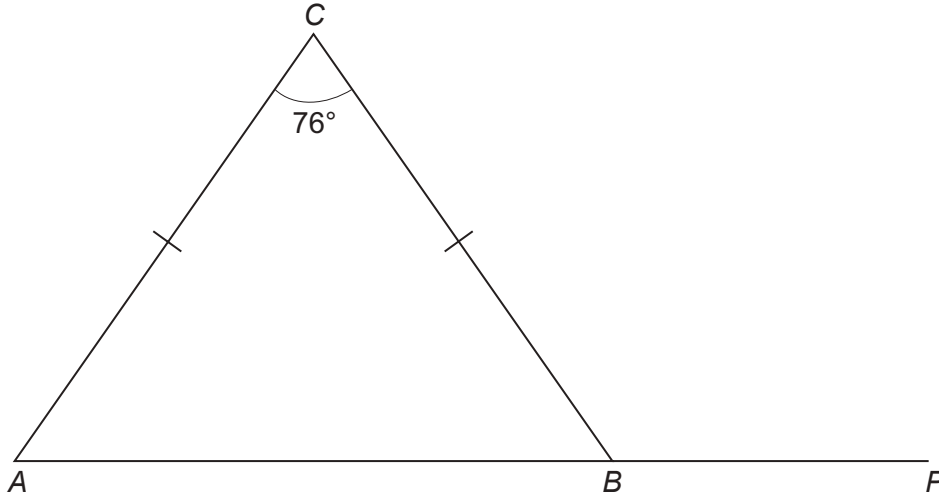

Diagram not drawn to scale

Calculate the size of \widehat{CBP} .
You must show all your working.

[3 + 2 OCW]

.....

.....

.....

.....

.....

.....

.....

.....

.....

.....

.....

.....

.....

.....

.....

.....



6. (a) Solve $\frac{m}{2} = 4.8$. [1]

.....

.....

.....

(b) Factorise the following.

(i) $6x - 15$ [1]

.....

.....

(ii) $y^2 + 4y$ [1]

.....

.....

(c) The n th term of a sequence is given by $3n - 20$.

(i) What is the value of the 6th term? [1]

.....

.....

(ii) Consider the following statement.

'There are no odd numbers greater than 50 in this sequence.'

Show that this statement is incorrect. [1]

.....

.....

.....



7. Two fair spinners are divided into quarters as shown below. One spinner shows the values 10, 20, 30 and 40. The other spinner shows the values 1, 2, 3 and 4.

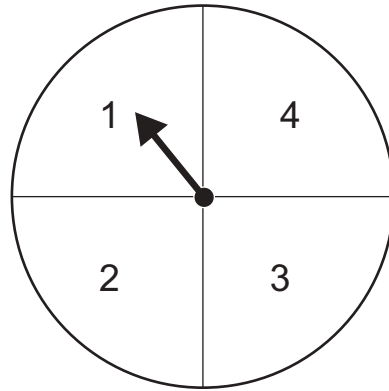
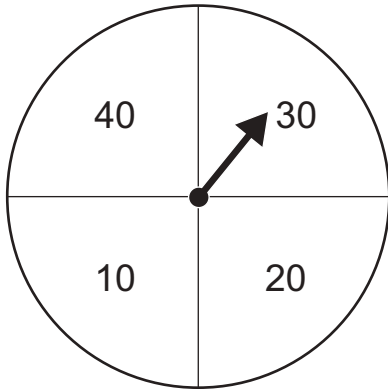

The two spinners are spun and the values shown are added together to form a number. For example, the diagram above would form the number 31.

Consider all the possible numbers that can be formed. Calculate the probability that the spinners will form a number that is a multiple of 7. You must show all your working in order to justify your answer.

[4]

.....

.....

.....

.....

.....

.....

.....

.....

.....

.....

.....

.....

.....

.....

.....

.....

.....

.....

.....

.....

.....

.....

.....



8. (a) Calculate the approximate difference in length between 1 mile and 1.5 km.
Give your answer in metres.

[3]

.....

.....

.....

.....

.....

.....

.....

(b) Convert an area of 4 m² into cm².

[2]

.....

.....

.....

.....

.....

4 m² = cm²

3300U401
09



9. $ABCE$ is a square.

Calculate the area of the shape $ABCDE$ shown below.

[5]

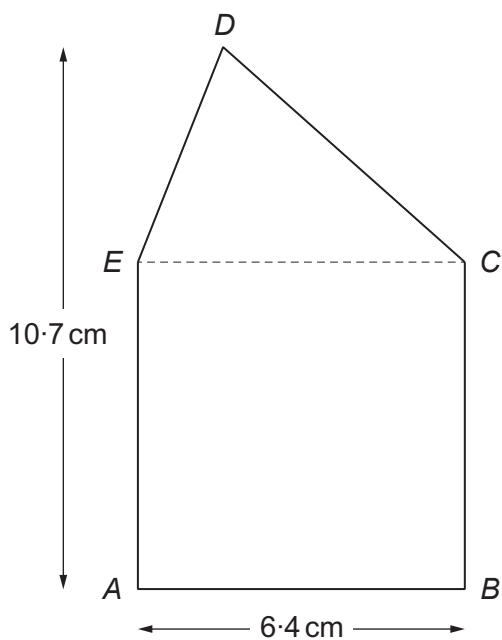

Diagram not drawn to scale

.....

.....

.....

.....

.....

.....

.....

.....

.....

.....

.....

.....

.....

.....

.....

.....

.....

.....

.....

.....

.....

.....



10. (a) A number is decreased by 12% of its value.
This is done 3 times, each time decreasing the previous value by 12%.
Circle the multiplier that you would use to find the value after the 3 decreases. [1]

$\times 0.36$

$\times 0.88^3$

$\times 0.12^3$

$\times 0.3^{12}$

$\times 0.3^{88}$

- (b) Calculate the percentage change when 42.5 is increased to 45.9. [3]

.....

.....

.....

.....

.....

11. Display the following information in a Venn diagram. [3]

- Universal Set (ϵ): Integers between 74 and 80 inclusive.
- Set A: Even numbers.
- Set B: Multiples of 3.



12. The table below shows some of the values of $y = x^2 + 4x - 1$ for values of x from -5 to 2 .

x	-5	-4	-3	-2	-1	0	1	2
$y = x^2 + 4x - 1$	4	-1	-4		-4	-1	4	

(a) Complete the table by finding the value of y for $x = -2$ and for $x = 2$. [2]

.....

.....

.....

(b) On the graph paper opposite, draw the graph of $y = x^2 + 4x - 1$ for values of x from -5 to 2 . [2]

(c) Draw the line $y = 2$ on the graph paper.
Write down the values of x where the line $y = 2$ cuts the curve $y = x^2 + 4x - 1$. [2]

Values of x are and



13. Jonathan writes a whole number on a card.

- The number is between 55 and 83 inclusive.
- The square root of the number is greater than 8 but less than 9.
- The highest common factor (HCF) of 49 and the number is 7.
- $\frac{3}{5}$ of the number is a multiple of 6.

What number is on Jonathan's card?

[3]

.....

.....

.....

.....

.....

.....

.....

.....

.....

.....

.....

.....

.....

.....

.....

.....

.....

.....

.....

.....

.....

.....

.....

.....

The number on Jonathan's card is



15. (a) What is the gradient of the straight line with equation $6y = 3x + 7$?
Circle the correct answer.

[1]

$\frac{1}{2}$

6

2

3

$\frac{7}{6}$

.....

.....

.....

- (b) What is the value of y at the point where the line $5x + y + 3 = 0$ crosses the y -axis?
Circle the correct answer.

[1]

0

-5

3

-3

$\frac{5}{3}$

.....

.....

.....

- (c) What are the coordinates of the point where the lines with equations $x + y = 7$ and $x - y = 3$ intersect?
Circle the correct answer.

[1]

(4, 3)

(7, 4)

(5, 2)

(3, 7)

(-5, 2)

.....

.....

.....



17. Alwena regularly travels from Anglesey to Cardiff to attend meetings. For each meeting, she chooses one of three ways to travel: by plane, train or car. The probability of a meeting being held on a Saturday is 0.08. The probability that Alwena travels by plane to a meeting is 0.15. The probability that she travels by train is 0.45. Her decision on how to travel is independent of the day on which the meeting is held.

(a) Complete the following tree diagram.

[3]

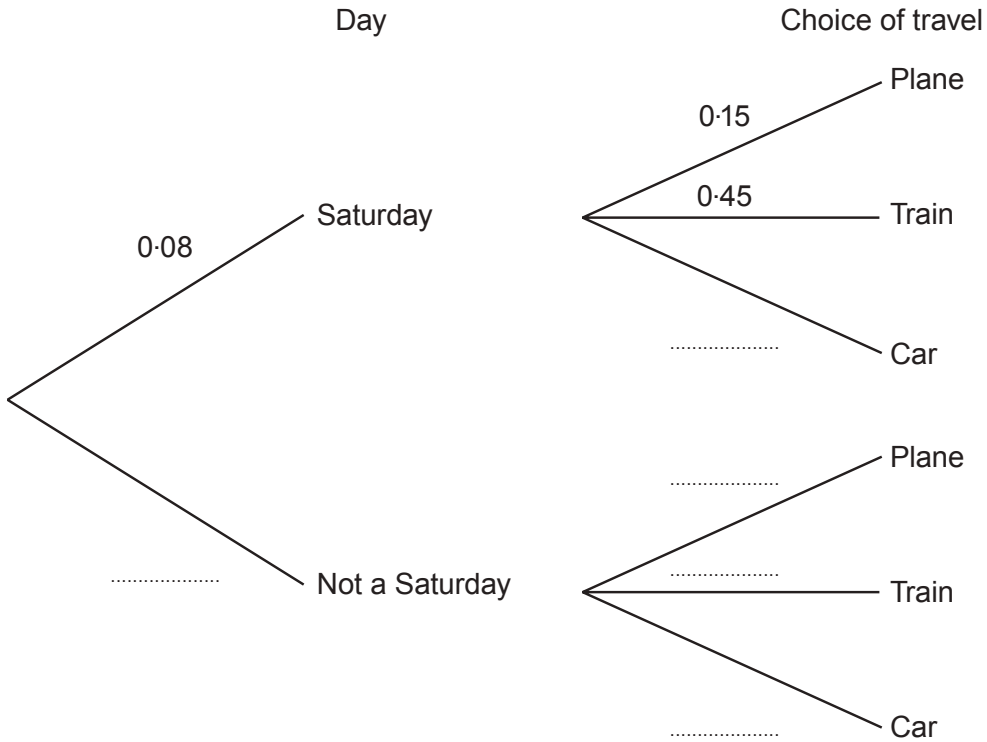

.....

.....

.....

(b) A meeting is chosen at random. Calculate the probability that the meeting is held on a Saturday and that Alwena travels by plane or by car. [3]

.....

.....

.....

.....



18. The diagram below shows two right-angled triangles ABC and APQ .
 $AB = 8.2$ cm, $BC = 6.4$ cm and $PQ = 7.9$ cm.

$$\hat{CAQ} = 90^\circ.$$

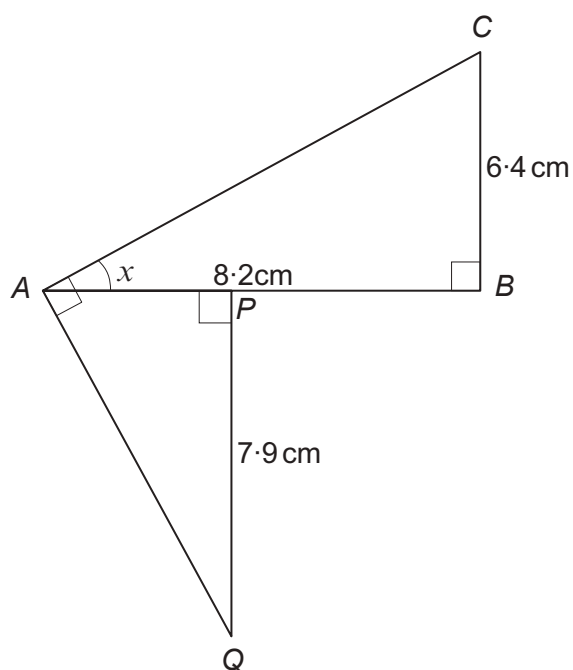

Diagram not drawn to scale

- (a) Calculate the size of angle x .

[3]

.....

.....

.....

.....

.....

- (b) Calculate the length AQ .

[4]

.....

.....

.....

.....

.....

.....

.....

.....



